

4

3

2

1

REVISIONS					
ZONE	REV.	DESCRIPTION / PURPOSE OF CHANGE	BY	YEAR/MM/DD	APPR.
	1.2	INITIAL RELEASE OF DOCUMENT	NT	2024-03-14	
A1	2.1	ADD TABLE 1 & CLARIFY CERTAIN DIMS	NT	2024-09-26	

D

D

C

C

B

B

A

A

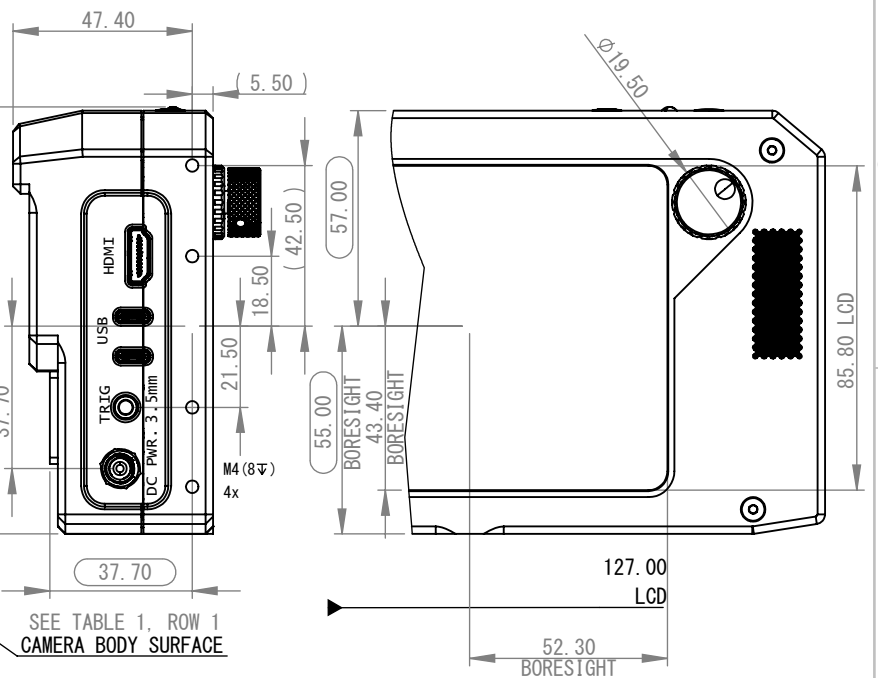
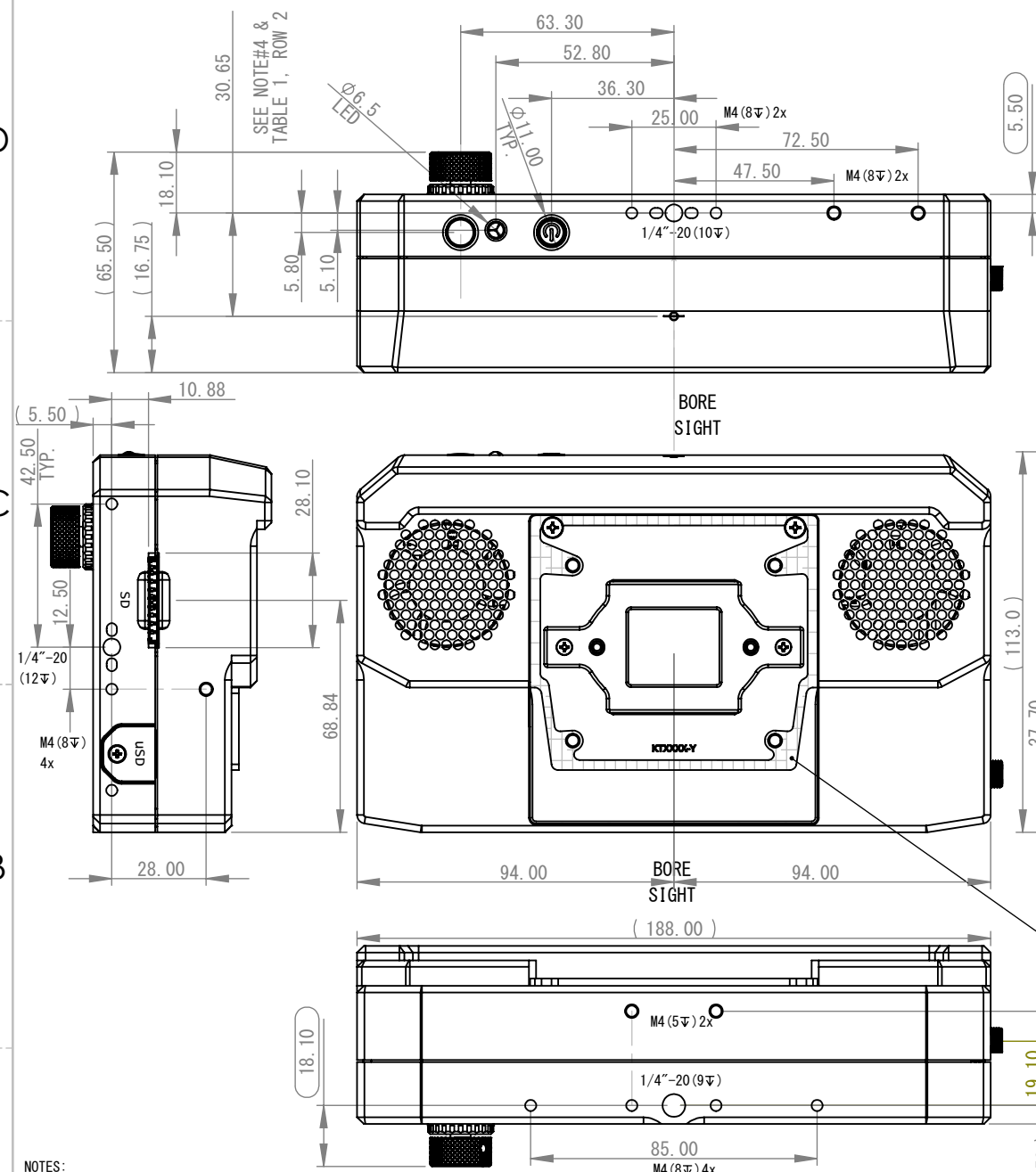

NOTES:

1. THE DIMENSIONS SHOWN ARE FOR INFO ONLY. USER MUST VERIFY THAT THE DIMS ARE SUITABLE FOR THEIR REQUIREMENTS.
2. KRON TECHNOLOGIES INC IS NOT RESPONSIBLE FOR DAMAGES OR LOSS THAT MIGHT OCCUR FROM USE OF THE INFO PROVIDED HEREIN.
3. INFO OR DIMENSIONS MAY CHANGE WITHOUT NOTICE. USER MUST ALWAYS CONTACT KRON TECHNOLOGIES support@krontech.ca BEFORE USE TO CONFIRM CURRENT REVISION OF THIS DRAWING.
4. LOCATION OF SENSOR CURRENT IMAGE PLANE. CORRECTED FOR PRESENCE OF FILTER GLASS (1.1mm THK.) & SENSOR GLASS IN OPTICAL PATH.

PROPRIETARY AND CONFIDENTIAL  
 © 2024  
 THE INFORMATION CONTAINED IN THIS DRAWING IS THE SOLE PROPERTY OF Kron Technologies.  
 ANY REPRODUCTION IN PART OR IN WHOLE WITHOUT THE WRITTEN PERMISSION OF Kron Technologies IS PROHIBITED.

UNLESS OTHERWISE SPECIFIED:  
 DIMENSIONS ARE IN: mm  
 TOLERANCES: NOT APPLICABLE  
 FINISH: BLACK ANODIZE  
 MATERIAL: SEE NOTES

INITIALS DATE  
 DRAWN BY: NT 24/03/06  
 CHECKED: --  
 Ref. Orig. KT No.: --  
 Other Ref.:

Kron Technologies, BC, Canada, V5A 2W4  
 DWG. TITLE: Customer Drawing, 4K12-Q12  
 NUMBER: KD0020  
 REV.: 2.1  
 SCALE: 1:2 WEIGHT: 1.22Kg excl. MOUNT SHEET 1 OF 1

TABLE 1 (& REFER TO NOTE#4)		
1	CAMERA BODY SURFACE	37.70
2	CORRECTED SENSOR PLANE	30.65
RESULT	SENSOR PLANE SET-BACK	7.05

4

3

2

1